



PRODUCT SHEET

534-D West 2nd Street

Elgin, TX 78261

Phone 512.285.2462

Fax 512.285.2464

info@johnsonbaggingequipment.com

www.johnsonbaggingequipment.com

MODEL NUMBER: AD108LS-DUPLEX

Product Type: Duplex belt fed bagging scale

Features:

- 2 Feeder Belts to receive the product from a supply bin and feed it upon demand to the weigh hoppers.
- 2 Independent weigh hoppers. As one hopper is discharging the other hopper can be filling.
- 1 common bag spout.
- 10-110 lbs. weight range
- Hinged swing-away lower section for easy cleaning and access to the weigh hoppers.
- Direct drive gear reduction boxes eliminating chains and sprockets. Self-cleaning tail & drive pulleys.
- Designed and built to run thousands of bags a day and do it year round.

Capacity:

- Up to 20 Bags per minute; 25 tons per hour.

Description:

- All of our belt fed bagging machines have inlets to the belts larger than any in the industry. 14" wide x 18" long, duplex having two of them. These feeder belts are designed to move products ranging from hard to flow to free-flowing products out of supply bins and feed it into weigh hoppers upon demand. Front & back access door for easy access to the belts. Open bottom design to prevent product build up underneath the belt.

Controls:

- See "Controls" to learn how these machines run, weigh product and what features make our controls so unique and second to no others in the industry.

The Johnson & Sons advantage:

- Every piece of Johnson equipment is built to your design needs
- The most accurate bagging scales on the market
- The industry standard in customer service
- Quick and easy maintenance and repair



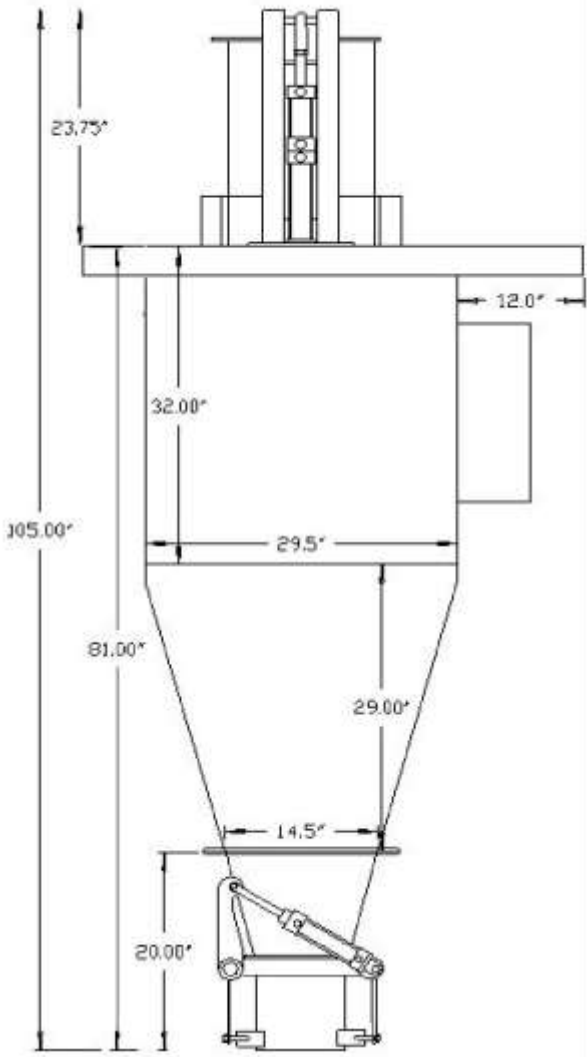

SIDE VIEW

FRONT VIEW

